



IMPORTANT: Please take the time to read through the ENTIRE instructions prior to starting any work. These instructions include the installation of a Tile Flashing Skirt which is sold separately.

PRECAUTIONS:

1. The solar attic fan is fully functional out of the box. THE FAN WILL OPERATE AS SOON AS THE SOLAR PANEL IS EXPOSED TO THE SUN. PLEASE USE CAUTION AND AVOID THE FAN BLADES DURING INSTALLATION.
2. Ensure normal safety precautions are taken when using tools, ladder and walking on roofs.
3. Do not cut any structural members in the house.
4. Install only in dry weather.

TOOLS/MATERIALS NEEDED

- | | |
|-----------------------|---------------------|
| ■ Caulk | ■ Reciprocating Saw |
| ■ Caulking Gun | ■ Safety Goggles |
| ■ Ladder | ■ Soft Cloth/Towel |
| ■ Marking Pencil | ■ Stud Finder |
| ■ Measuring Tape | ■ String |
| ■ Philips Screwdriver | ■ Utility Knife |

SOLAR ATTIC FAN KIT PARTS:

- A. Solar Attic Fan Unit
- B. (6) Phillips Head Stainless Steel 1 1/2" Screws

Additional Part (sold separately):

- C. Tile Flashing Skirt with Rubber Membrane

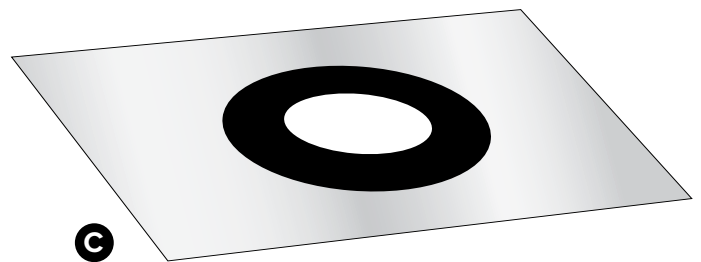
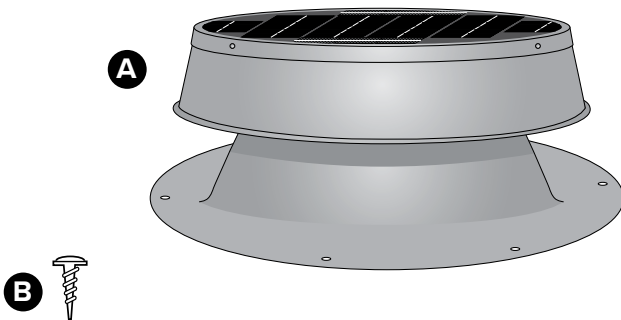

IMPORTANT Choose Where to Install Unit:

When determining location of the unit, try to place the solar attic fan on the south side of the roof, also consider potential problems such as objects shading the unit during certain times of the day. If the roof has no ridge vent, the center of the unit should be about 2 feet down from the roof ridge. If there is a ridge vent, the center of the unit should be about 5 feet down from the roof ridge.

STEP 1

Choose location for the solar attic fan, south exposure is best. Once the location is determined, carefully remove the surrounding tiles. Remove enough tiles to accommodate the flashing skirt (C).

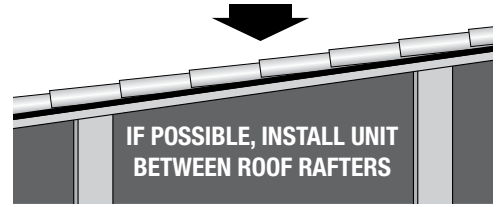

STEP 2

DETERMINE SIZE OF HOLE NEEDED FOR YOUR INSTALLATION:

On 24" on center construction, center the fan between the rafters and cut a 19" hole. On 16" on center construction, the installer can either cut a 14" hole between the rafters or cut a 19" hole with the roof rafter running through the hole (see "Option" illustration in Step 3).

Hammer a nail at the center of the location chosen for the solar attic fan between rafters. The center of the unit should be about 2 feet down from the ridge.

19" HOLE: Attach a string to the nail. Measure 9.5" of string and attach a marking pen to the string, see diagram. Scribe a 19" circle onto the roof shingles.

14" HOLE: Attach a string to the nail. Measure 7" of string and attach a marking pen to the string, see inset. Scribe a 14" circle onto the roof shingles.

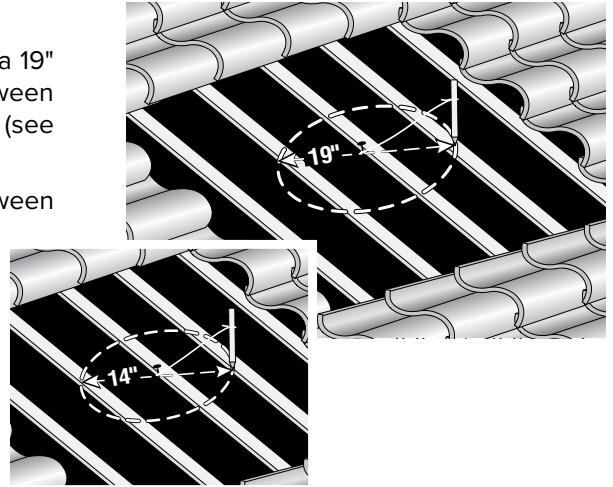

STEP 3

With a reciprocating saw, cut the diameter of the hole. **NEVER CUT THROUGH ANY ROOF RAFTERS. LEAVE ALL FRAMING MEMBERS IN PLACE.**

IMPORTANT: The solar attic fan must be installed between the roof rafters OR over a roof rafter. **DO NOT CUT THROUGH ANY FRAMING MEMBER.** Only remove roof sheathing.

OPTION:
16" ON CENTER
WITH 19" HOLE

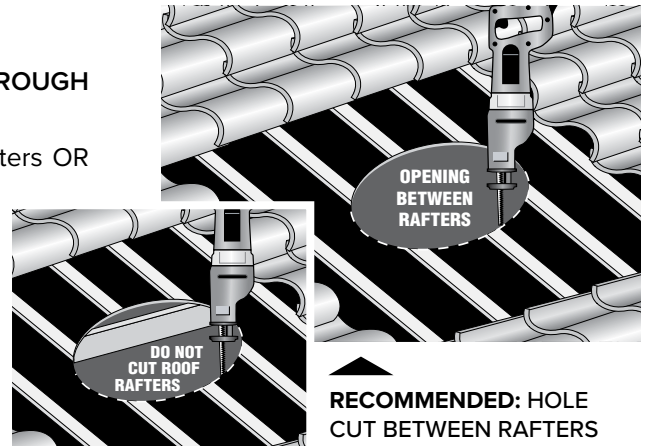

STEP 4

Prior to removing the (4) screws holding the solar panel in place, mark both the solar panel ring and the fan housing. The marks will help to realign the screw holes when you are ready to reassemble the unit.

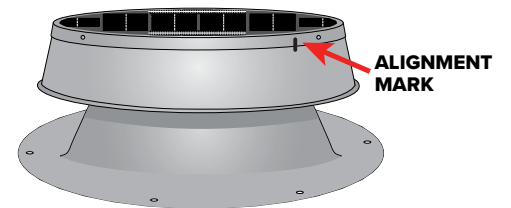

STEP 5

Remove the (4) screws on the solar panel ring and pull up to disconnect. Place the solar panel upside down on a soft cloth or towel to prevent damaging the solar panel and set it aside.

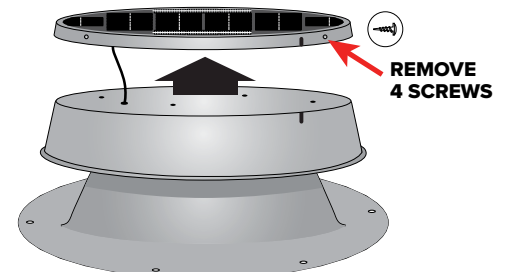

STEP 6

Carefully turn the unit back upright. It's important that the position of the housing and flashing are the same when the housing is reattached. Make two marks on the unit: one on the housing and another that lines up with it on the flashing.

Remove the (4) screws that secure the housing to the flashing "L" brackets. Pull up on the housing to remove it from the flashing. Temporarily place the housing and removed screws to the side.

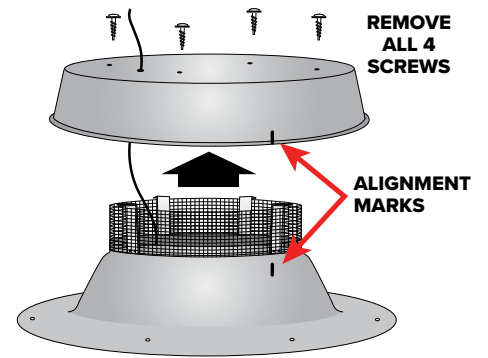

STEP 7

Carefully turn the solar attic fan upside-down and place it on a soft cloth to prevent damage to the solar panel. Locate the plastic wire clip on the inside wall of the flashing. Remove the screw on the clip to remove it from the flashing (the wire will stay connected to the clip - see closeup).

NOTE: Take care not to damage the fan blades.

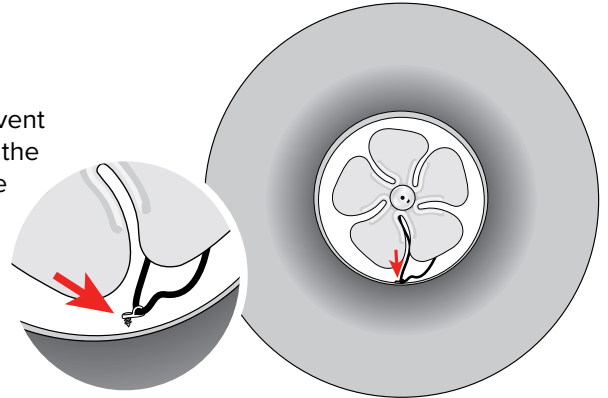

STEP 8

Remove all (4) housing "L" brackets by unscrewing the (2) self-tapping screws holding each bracket in place. Set aside the bracket and (8) screws.

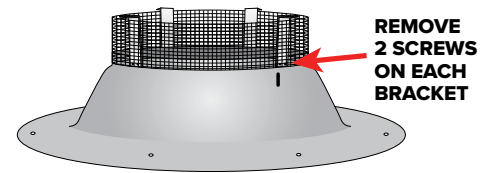

STEP 9

Center the solar attic fan flashing over hole cut in Step 3 and mark around the flashing footprint onto the furring strips. Remove the portion of the furring strips where the flashing will be installed (allowing the flashing to sit directly on the roof sheathing). Leave all other furring strips in place.

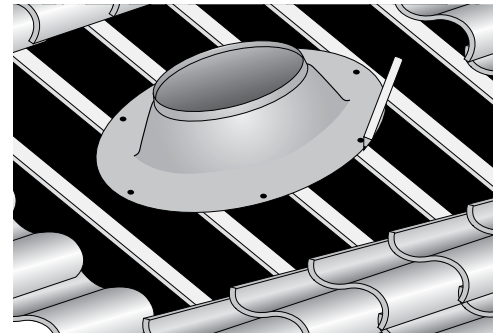

STEP 10

Place the flashing skirt (C) over the flashing. Press down the rubber ring all around the flashing.

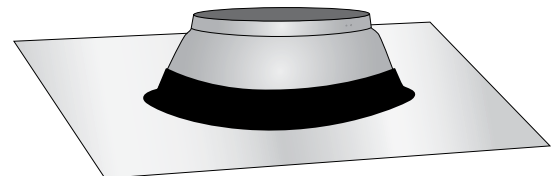

STEP 11

Replace the "L" Bracket Screen Assembly removed in Step 8 using the (8) screws (two screws per bracket).

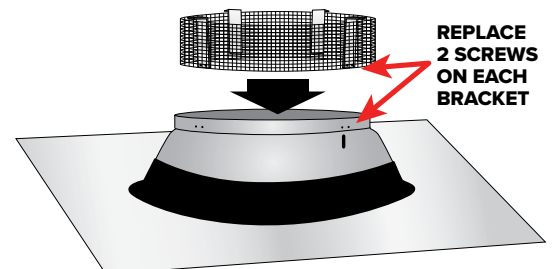

STEP 12

Carefully turn over the unit and place it on a soft cloth to prevent damaging the solar panel. Locate the plastic wire clip and reattach it to the flashing wall by replacing the clip screw (see closeup).

Place the housing on top of the flashing and line up the marks on the housing and flashing. Replace the (4) screws that were removed in Step 6.

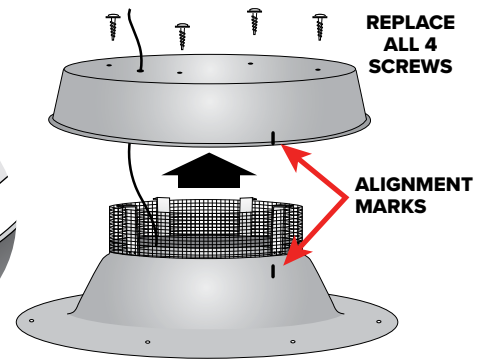
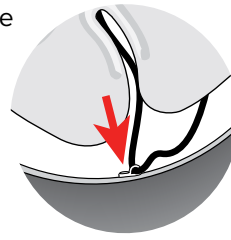

STEP 13

Place the solar panel ring over the fan housing and line up the marks on the ring and fan housing. Reattach the solar panel ring using the (4) screws removed in Step 5.

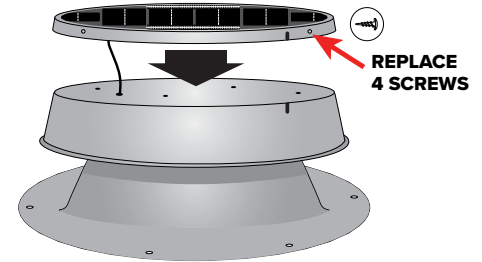

STEP 14

Caulk the underside of flashing. Two concentric rings of caulking material is sufficient.

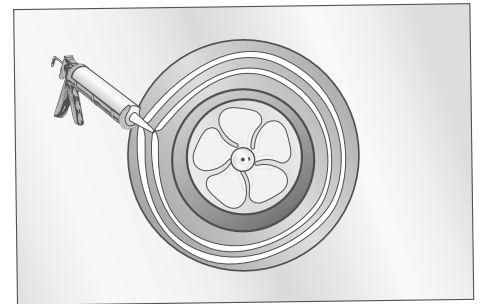

STEP 15

Carefully turn the unit back over and place on the roof centered over the hole cut in Step 3. Secure to the roof with the provided (6) Philips head screws (B) through the pre-drilled holes. Bend or roll up the flashing skirt so that it is out of the way as needed until all (6) screws are secured.

NOTE: Local Building Code requirements may specify anchoring that requires additional screws installed in the flashing.

Florida Dept. of Community Affairs:

http://www.floridabuilding.org/pr/pr_app_srch.aspx

Texas Dept. of Insurance:

<http://www.tdi.state.tx.us/wind/prod/indexrv.html>

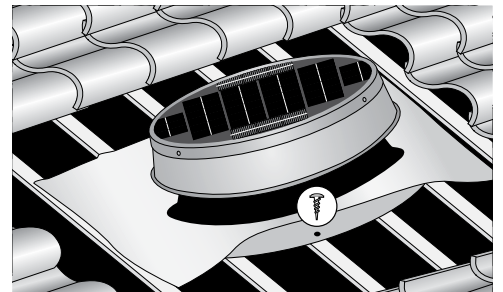

STEP 16

At the HIGH side of the roof towards the ridge, replace the tiles over the flashing skirt. Cut tiles to fit around flashing. Some furring strips may need to be replaced on top of flashing footprint to support tiles.

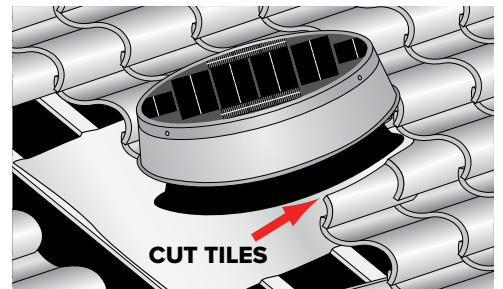

STEP 17

Replace the tiles on the LOW side of the roof, but keep the skirt above the tiles and reshape the skirt aluminum to form around the tiles. Apply sealant on the underside of the tile skirt to secure the skirt to the tiles.

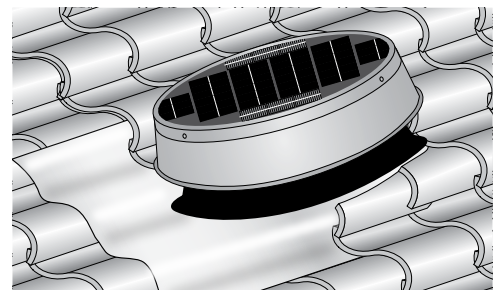



Solar Attic Fan Limited Lifetime Warranty

Natural Light Energy System (hereinafter NLES) warrants any solar attic fan manufactured by NLES to be free from defects in materials and workmanship to the original residential purchaser (hereinafter CONSUMER) from the date of purchase. All aspects of the Warranty are subject to the following limitations, terms and conditions.

1. DURATION OF WARRANTY

If a NLES solar attic fan (hereinafter "Equipment") is determined to have a defect in material or workmanship, NLES will, at its sole discretion, repair or replace the defective part at NO CHARGE to the CONSUMER, (excluding labor, and applicable shipping and handling costs) for the duration of the CONSUMER'S ownership of the original equipment (hereinafter "LIFETIME").

2. LIMITATIONS OF COVERAGE

This Warranty extends only to the CONSUMER for damage resulting from defects in materials and workmanship, it does not extend to damage caused by the CONSUMER'S neglect or abuse, or by accident, to damage caused by wind, hail or abnormal weather conditions, or to damage caused by acts of God, civil insurrection or extraordinary circumstances which are beyond the control of NLES.

NLES shall not be liable for any direct or indirect damage resulting from the use of the Equipment, and in no event shall the extent of the Warranty coverage exceed the purchase price of the Equipment.

NLES assumes no liability for the determination of the proper equipment necessary to meet a CONSUMER'S requirements, nor does it authorize others to assume such obligations on its behalf.

3. MISCELLANEOUS

In order to be considered for validation, all claims for Warranty coverage must be accompanied by a copy of the purchase agreement indicating the date of initial installation, NLES reserves the right to inspect the solar attic fan prior to honoring any Warranty claim.

This Warranty gives you specific legal rights, and you may have other rights which may vary from state to state. Any and all inquiries or claims under this Warranty must be submitted in writing to **Natural Light Energy Systems, Attn: Warranty Department, 10821 N. 23rd Avenue, Phoenix, AZ 85029** or by e-mail to info@solaratticfan.com.



To register your Solar Attic Fan, please visit
www.solaratticfan.com/warranty-registration.html



REGISTER NOW